

PM4 Monitor Disassembly/Reassembly Instructions

TOOLS REQUIRED: #0 or #1 Phillips head screwdriver
9/16" wrench

NOTE: Handle all components very carefully.

concept 2
ROWING

MORRISVILLE, VERMONT USA

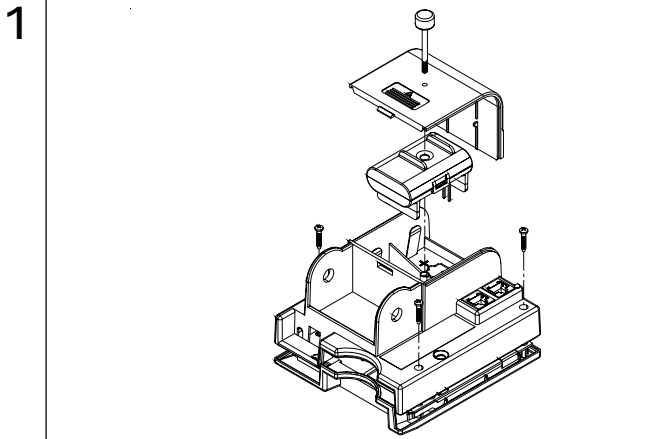

1 Unplug all wires and remove the PM4 from the indoor rower. Remove the battery door fastener and remove the battery pack (shown) or D cell batteries. Remove the four PM4 case screws.

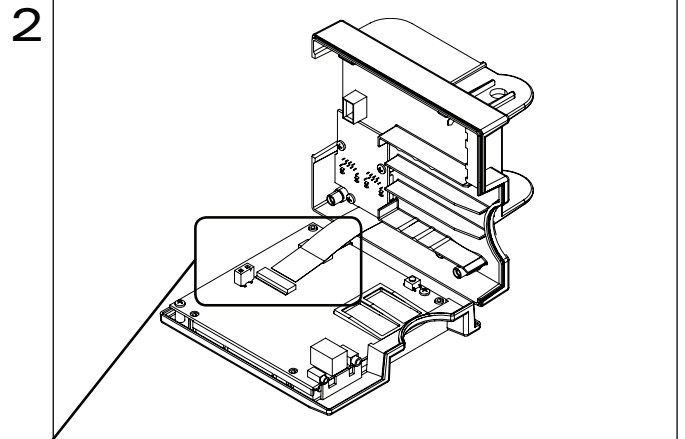

2 Carefully separate the case back from the case front, noting the position of the metal battery contacts.

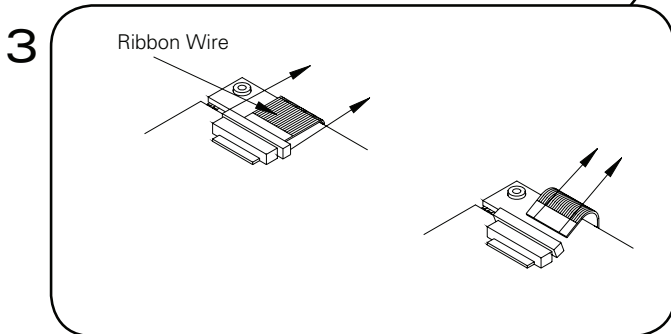

3 Detach the two flex cables from their sockets on the circuit board:

1. Pull the flex cable lock to the right and up.
2. Pull flex cable out of socket.

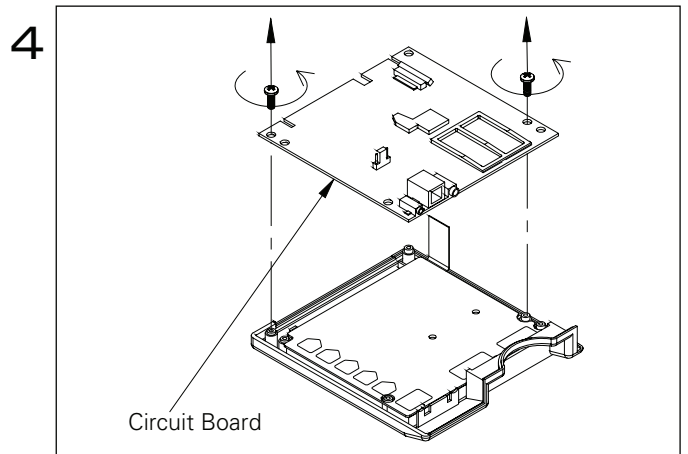

4 Remove the two Phillips head circuit board screws and remove the circuit board.

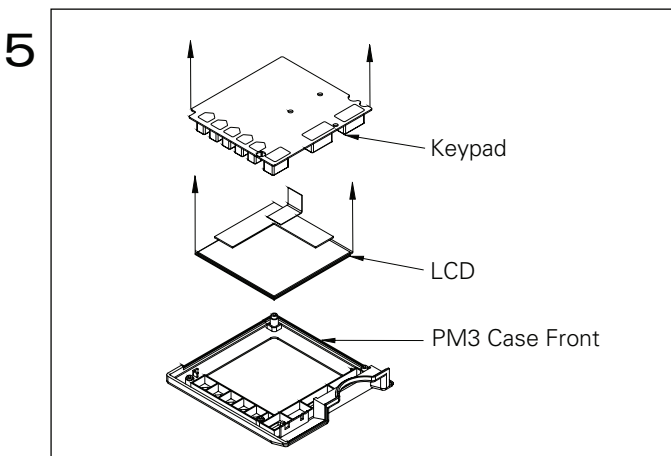

5 Remove rubber keypad and LCD from the PM4 case front.

- 6 Reassemble in reverse order of disassembly.
- IMPORTANT TIPS:**
- Carefully position the LCD and keypad in the PM4 case front.
 - Use the two holes marked with arrows for the two circuit board screws. Tighten the two screws evenly and firmly.
 - Be sure the flex cables are fully inserted in their sockets before pushing down and to the left to close the flex cable locks.
 - Be sure the metal battery contacts are positioned correctly and that the two assembly screws go through them.
 - The four case screws should be tightened firmly (4-6 in. lbs), but not stripped out.
 - You will be prompted by the PM4 to reset the language, date, and time. Note that internal workout memory will be lost.
 - If you have replaced the LCD, you may want to adjust the LCD contrast setting located at MAIN MENU > MORE > UTILITIES > SET CONTRAST.