

INSTALLING THE POLAR™ HEART RATE INTERFACE ON THE MODEL E INDOOR ROWER

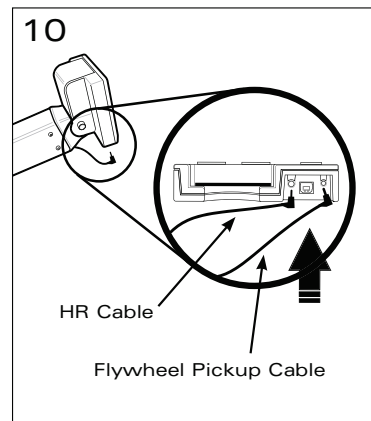

concept2.com

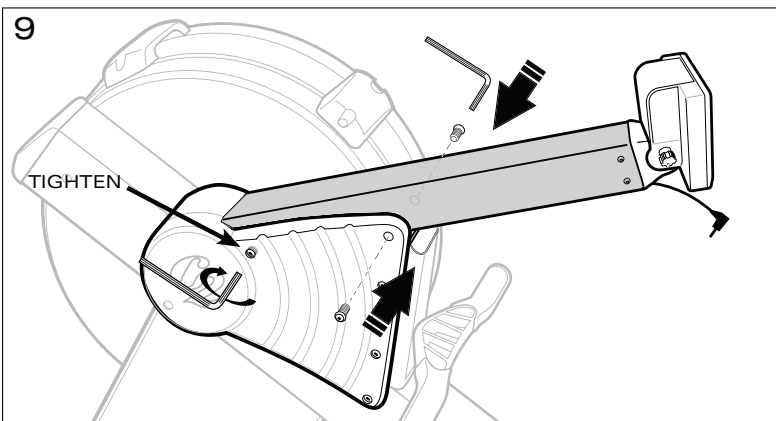
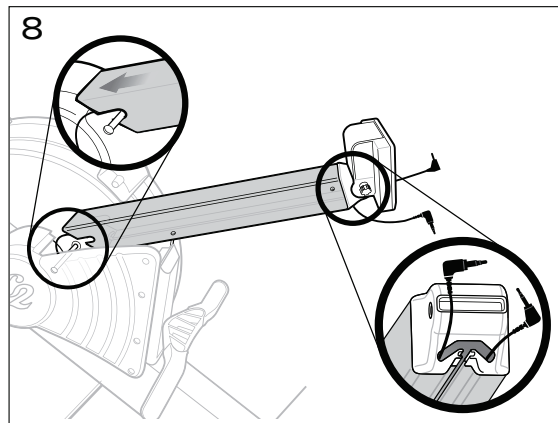
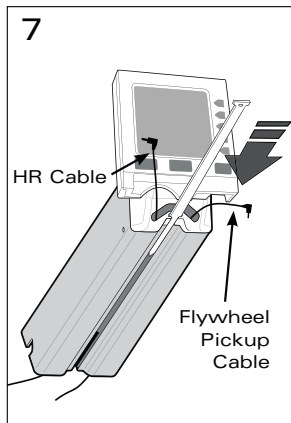
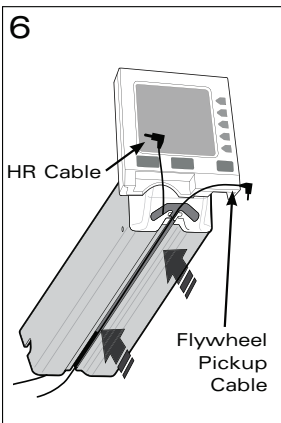
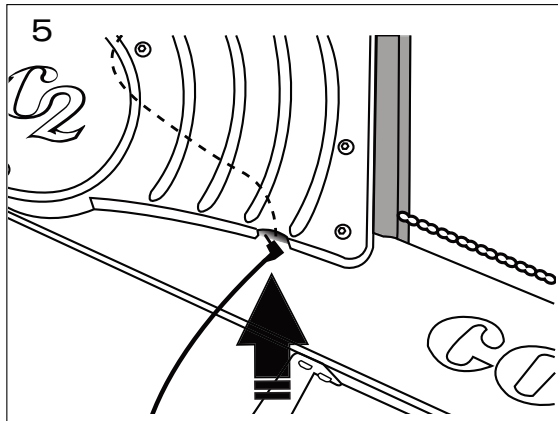
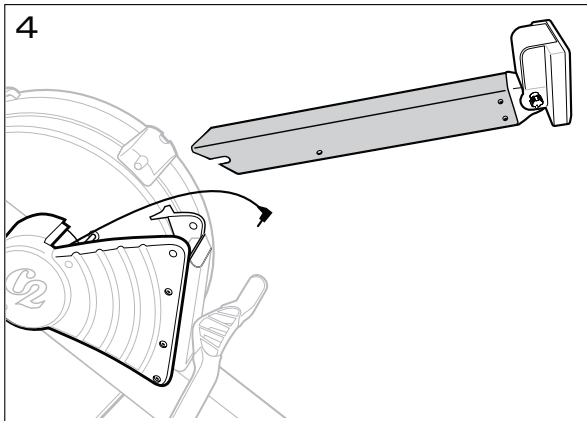
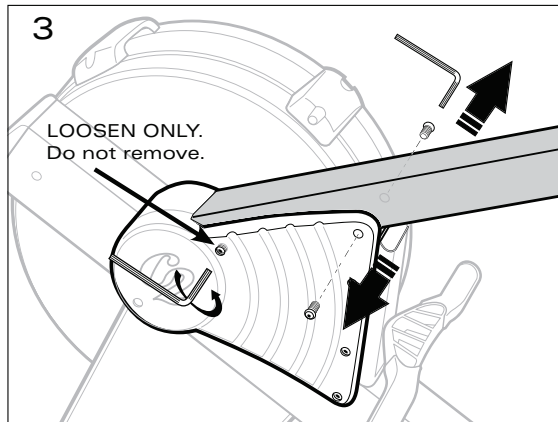
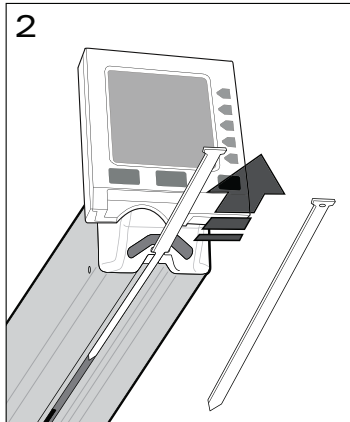
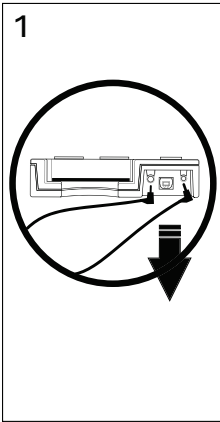

11

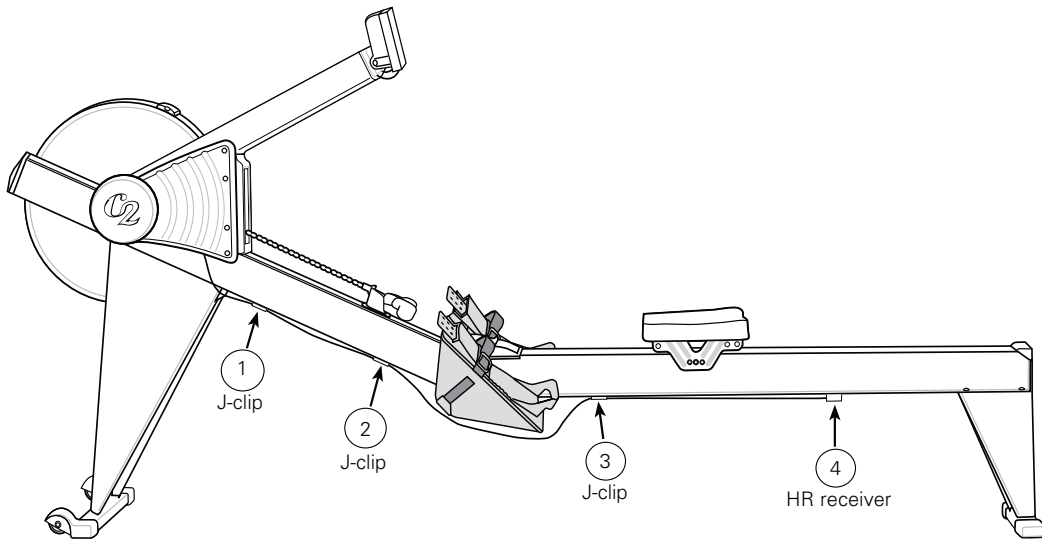

Note for Storage: Before disconnecting monitor from front end, remove receiver from VELCRO patch.

HOW TO WEAR POLAR™ (OR POLAR COMPATIBLE) HEART RATE MONITOR

1. WET THE ELECTRODE AREAS OF ELASTIC CHEST BELT

Wet the electrode area (the two rectangular areas on the underside of the chest belt) thoroughly under running water.

2. ATTACH THE CONNECTOR TO THE ELASTIC CHEST BELT

Position the letter L on the connector next to the word LEFT on the chest belt and snap the fastener.

3. SECURE THE ELASTIC CHEST BELT

Center the chest belt flat against your skin, as high under the pectoral muscles (breasts) as is comfortable. The logo should be right side up. Snap the second fastener. The chest belt should fit snugly and comfortably and allow for normal breathing.

4. ROW!

Your heart rate will be displayed in the center right display in all display modes. See photo at right.

NOTE: It sometimes takes a few minutes of exercise to achieve a consistent heart rate signal.



PM4

Precautions

- Thoroughly wipe your Polar elastic chest belt and connector dry after each use.
- Do not store in a non-breathable or plastic bag where moisture may become trapped. Store in a warm dry place.
- Do not expose your heart rate monitor to direct sunlight, extreme heat above 50° Celsius (122° Fahrenheit) or extreme cold below -10° Celsius (14° Fahrenheit).
- Do not bend or stretch the electrode strips on your chest belt, especially when storing.

Troubleshooting

What if the heart rate reading is erratic or totally absent?

NOTE: Occasionally the heart rate monitor will pick up bad data for a number of reasons. When the monitor recognizes bad data, the display will go blank rather than show the bad data. It will take five seconds or longer to re-establish and display accurate readings.

1. Repeat the electrode wetting procedure as described above. The electrodes must be wet to pick up accurate heart rate readings.
2. Make sure the connector is centered with electrodes flat against your skin, as high under the pectoral muscles as is comfortable.
3. Wash your elastic chest belt with mild soap and water, if you have not been doing so regularly.
4. Make sure your receiver is within the proper range to receive transmission (1 meter/3 feet from your chest belt).

5. Check the connection where the receiver cable plugs into the underside of the monitor. Check the connection between the cable and the receiver.
6. If you are exercising within range of strong electromagnetic signals the heart rate readings may elevate to abnormal levels. Common sources of electromagnetic signals are televisions, computers, cars, TV antennas, high voltage power lines and motor driven exercise equipment.
7. Signals from more than one HR monitor within the transmission range (1 meter/3 feet) may also cause incorrect readings. Check your surroundings and move away from the source of interference if possible.

NOTE: Two indoor rowers with heart rate hardware must be at least four feet (1.22 meters) apart to avoid interference.

If further troubleshooting assistance is needed, call Concept2 at 1.800.245.5676.